

SERVICE

SERVICE BULLETIN NO. 125

B
U
L
L
E
T
I
N

DATE: November 9, 1971

SUBJECT: Weight and Balance Data Sheet Correction

SERIALS AFFECTED: AALA-0001 thru AALA-0088, AALA-0090 thru AALA-0179, AALA-0181 thru AALA-0191, AALA-0193 thru AALA-0201, AALA-0203, AALA-0205 thru AALA-0214, AALA-0216 thru AALA-0219, AALA-0221 and AALA-0222, AALA-0224 thru AALA-0227, AALA-0229 thru AALA-0241, AALA-0243, AALA-0245 thru AALA-0251, AALA-0253, AALA-0258 thru AALA-0260.

TIME OF COMPLIANCE: Immediately

Some model AA-1A Trainer aircraft have been delivered from the factory with incorrect Weight and Balance Data Sheets included with the aircraft papers.

To correct this discrepancy, new Weight and Balance Data Sheets are being prepared and will be mailed via certified mail, to each affected aircraft owner by November 30, 1971.

To prevent improper loading of the affected aircraft in the interim period before receipt of new Weight and Balance Data Sheets, we have attached a sample corrected Weight and Balance Data Sheet to this Service Bulletin. The areas where errors may have occurred, are highlighted in red.

You are requested to immediately compare the attached sample with the Weight and Balance Data Sheet delivered with your aircraft and correct your data sheet as necessary.

PHS:pjr

AMERICAN AVIATION CORPORATION

Attachment

Distribution (B)

AMERICAN AVIATION CORPORATION

WEIGHT AND BALANCE DATA

MODEL AA-1A

TRAINER
Rev. 10-29-71

Date _____
 Serial No. _____
 "N" No. _____
 Scales used _____
 Prepared by: _____

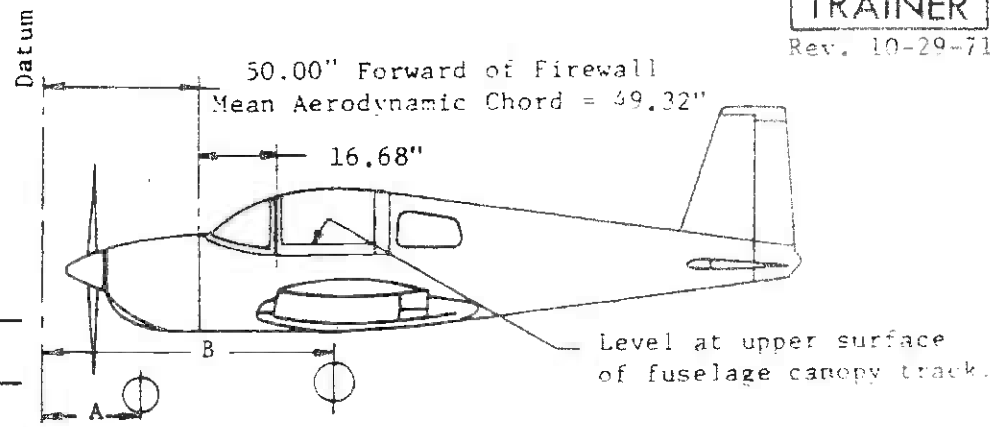

A = Nosewheel Sta. = _____
 B = Mainwheel Sta. = _____

AIRCRAFT WEIGHT, AS WEIGHED					
Position	Scale Reading	Tare	Net Weight	Reaction Arm	Moment
Left Wheel			x(B)	=	=
Right Wheel			x(B)	=	=
Nose Wheel			x(A)	=	=
TOTAL NET WEIGHT, AS WEIGHED			Total	Moment	=

Arm = $\frac{\text{Total Moment}}{\text{Net Weight}}$ = _____ = _____ Inches

* WEIGHT CORRECTED FOR PAINT AND EQUIPMENT SHORTAGE --- PLUS OIL REMOVAL

Items	Weight(lbs.)	C.G. Arm(in.)	Moment(lb.-in.)
* Net Weight As Weighed			
* Unusable Fuel	12.0	84.5	1014
Licensed Empty Weight			

(Gross Wt.) - (Licensed Empty Wt.) = Useful Load

() Lbs. - () Lbs. = () Lbs. Useful Load

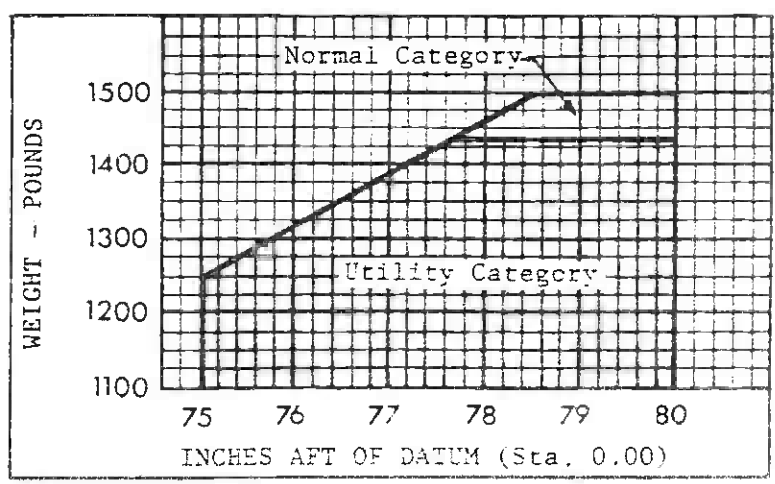

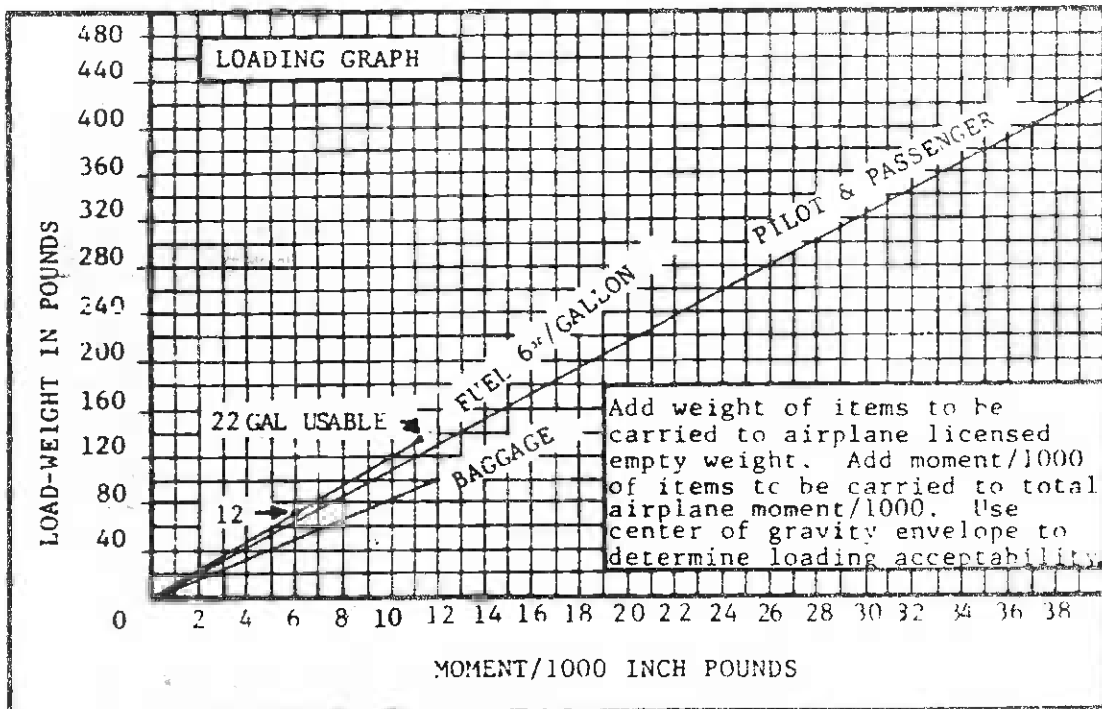
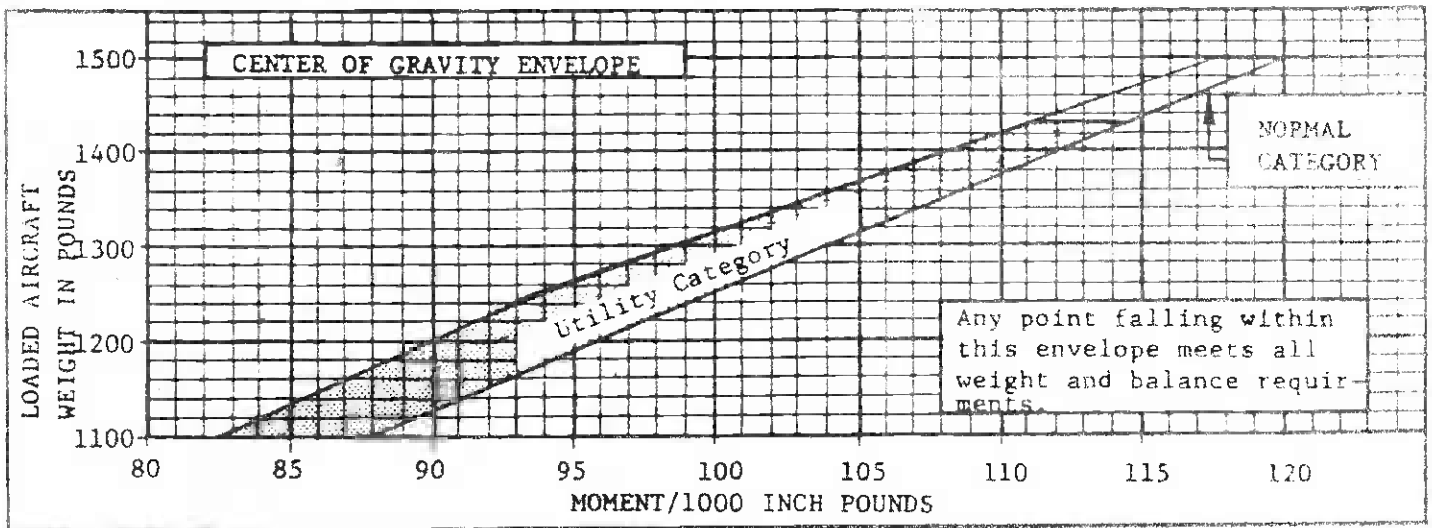

Sample Loading Problem: Empty Weight of _____ lbs., Moment of _____ in. lbs.
 (Normal Category Shown)

	Weight	Arm in Inches	Moment in thousands of in. lbs.
Empty Weight (Licensed)	()	()	()
Oil (Qts. 6) 1 Qt. = 1.875 lbs.	(11)	(39.0)	(.429)
Fuel (in excess of unusable)	(132)	(84.5)	(11.154)
Pilot and passenger	()	(92.5)	()
Baggage (allowable 100 lbs.)	()	(120.0)	()
Total Weight	()	()	()

Locate this point(;) on the center of gravity envelope graph, and if the point falls within the envelope, the above loading meets all balance requirements.

It is the responsibility of the airplane owner and the pilot to insure that the airplane is loaded properly. The empty weight C.G. and useful load are noted above for this airplane as delivered from the factory. If the airplane has been altered, refer to the latest approved repair and alteration form (FAA 337) for this information.

Subject: Weight and Balance Data Sheet Correction

As stated in American Aviation Corporation's Service Bulletin No. 125, attached is a new Weight and Balance Data Sheet for your aircraft. This Data Sheet supersedes the Data Sheet originally supplied with your aircraft.

You are requested to immediately insert this new Data Sheet into your aircraft papers file and destroy the obsoleted sheet.

AMERICAN AVIATION CORPORATION

Subject: Weight and Balance Data Sheet Correction

As stated in American Aviation Corporation's Service Bulletin No. 125, attached is a new Weight and Balance Data Sheet for your aircraft. This Data Sheet supersedes the Data Sheet originally supplied with your aircraft.

You are requested to immediately insert this new Data Sheet into your aircraft papers file and destroy the obsoleted sheet.

AMERICAN AVIATION CORPORATION