

DATE: February 20, 1973
SUBJECT: Carburetor Air Box Modification
SERIALS AFFECTED: AA5-0001 through AA5-0300
TIME OF COMPLIANCE: Within the next 100 hours of operation or at the next scheduled inspection, whichever occurs first.

GENERAL

Field reports have been received which indicate that the steel stem aluminum pop type rivets which are used to attach the steel adapter flange assembly to the carburetor air box are working loose in service. In order to reinforce this attachment area, production aircraft AA5-0301 and on will be produced with solid rivets at this attachment point.

To eliminate this condition, it is recommended that the following be accomplished on the above affected aircraft at the next scheduled inspection, but no later than 100 hours time in service from the date of this Bulletin.

MODIFICATION

Remove the existing seven (7) pop rivets as shown on Figure 1 and replace with seven (7) rivets, part no. MS20470AD-4. It is not necessary to remove the air box assembly from the carburetor to incorporate this modification. Visually inspect the entire air box.

Remove (7) existing Pop Rivets. Replace with (7) MS20470AD-4 Solid Rivets.

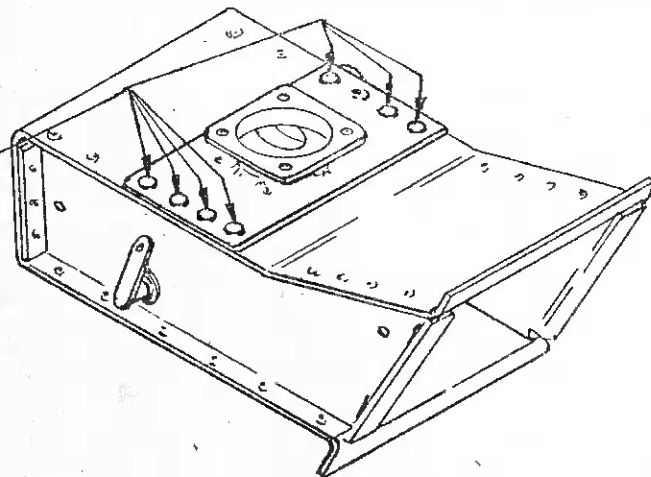

CREDIT ALLOWANCE

FIGURE 1. CARBURETOR AIRBOX RIVET REPLACEMENT

A labor credit allowance of .5 hours at the dealer's prevailing shop rate will be available for performing the above modification on all affected aircraft in or out of warranty.

All work must be performed or authorized by a Grumman American Aviation Corporation Dealer or representative and a completed Warranty Claim Form No. AA-740 submitted to the factory prior to August 31, 1973 for credit allowance.

Prices subject to change without notice.

GRUMMAN AMERICAN AVIATION CORPORATION

Distribution (B)