



SERVICE LETTER

SL 2003-3
ATA 5711

DATE: April 7, 2003

SUBJECT: **OUTBOARD WING SPAR ATTACH BOLTS**

MODEL / SERIALS AFFECTED: AG-5B S/N 10203, 10204, 10207 and S/N 10209 through 10215

TIME OF COMPLIANCE: **WITHIN THE NEXT 25 HOURS TIME IN SERVICE OR AT THE NEXT SCHEDULED INSPECTION, WHICHEVER OCCURS FIRST**

GENERAL:

It has been determined that there is insufficient shoulder engagement of the outboard wing panel spar attach bolts on the affected aircraft due to an incorrect washer stack-up under the bolt head. This condition could lead to loosening of the bolts and possible damage to the bolts and/or bolt holes.

The standard method of attachment of the outboard wing panel is the use of two (2) P/N 901044-1 Shoulder Bolts, one on either side of the spar. These shoulder bolts should have three (3) AN960-616 washers under the head of each bolt. It has been determined that six (6) washers may have been installed under the head of each Shoulder Bolt during the manufacturing process. (Figure 2)

One or both wings installed on the affected aircraft may have their outboard wing panels attached using an alternate method of attachment. This method uses two (2) AN8-10A bolts with one (1) AN960-816 washer each in the place of the 901044-1 bolts and AN960-616 washers. It has been determined that three (3) AN 960-816 washers may have been installed under the head of these bolts during the manufacturing process. (Figure 2)

ACTION:

Within the next twenty-five hours time in service or at the next scheduled inspection, whichever occurs first, accomplish the following:

1. Prepare the aircraft for safe maintenance.

2. Remove the access panels forward and aft of the outboard spar attach point and locate the outboard spar attach bolts. (Figure 1)
3. Visually inspect the spar attach bolts and determine the bolt type. (Figure 3)
4. If 901044-1 shoulder bolts are found, determine the number of AN960-616 washers installed under the head of each bolt.
 - a. If three (3) washers are installed under the head of each bolt (Figure 2), no further action is required. Comply with steps 12-14.
 - b. If six (6) washers are installed under the head of each bolt (Figure 2), proceed with steps 6-14.
5. If AN8-10A bolts are found, determine the number of AN960-816 washers installed under the head of each bolt.
 - a. If one (1) washer is installed, no action is required. Comply with steps 12-14.
 - b. If three (3) washers are installed under the head of the bolt (Figure 2), proceed with steps 6-14.
6. Remove both bolts and washers from the spar.
7. Using a light and mirror, inspect each attach hole for damage. If hole damage or an out-of-round condition is found, contact the Tiger Aircraft Service Department for repair instructions.
8. Inspect the bolt for condition using a 10-power magnifying glass. Any cracks, damage to threads or scoring of the bolt shoulder is grounds for rejection of the bolt.
9. Reinstall the 901044-1 shoulder bolts with three (3) AN960-616 washers under the head of each bolt and torque to 60-85 inch pounds.
10. Reinstall the AN8-10A bolts with one (1) AN960-816 washer under the head of each bolt and torque to 290-410 inch pounds.
11. Repeat steps 1-10 for the opposite wing.
12. Reinstall access covers.
13. Record compliance in the aircraft log book.
14. Fill out the attached compliance card and return to Tiger Aircraft, LLC

Tiger Aircraft, LLC will allow up to 1.25 hours of Warranty Labor for compliance with this Service Letter when submitted on a TA Warranty Claim Form.

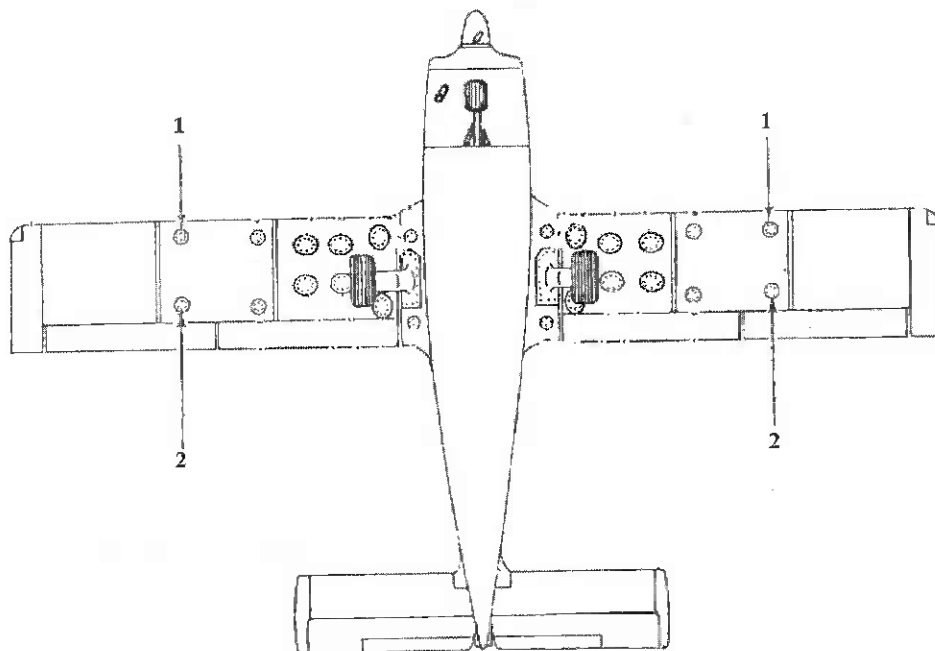

1. Forward Access Panels
2. Aft Access Panels

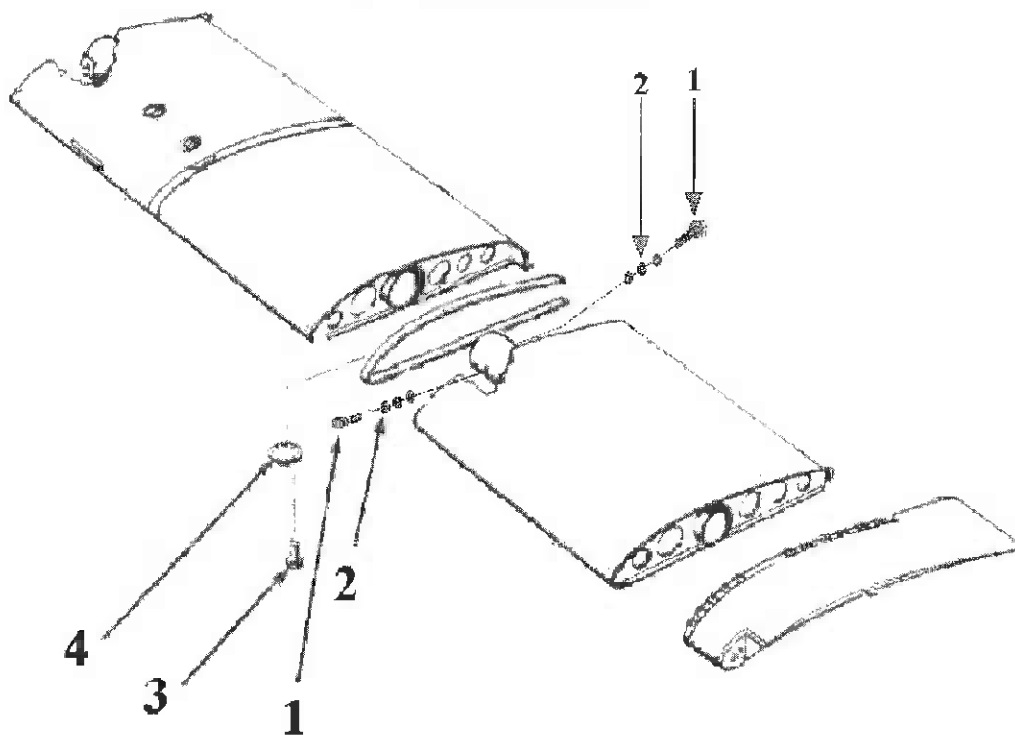

1. 901044-1 Shoulder Bolt or AN8-10A Bolt
2. AN960-616 Washer (3) or AN960-816 Washer (1)
3. Screw
4. Access panel

Figure 1

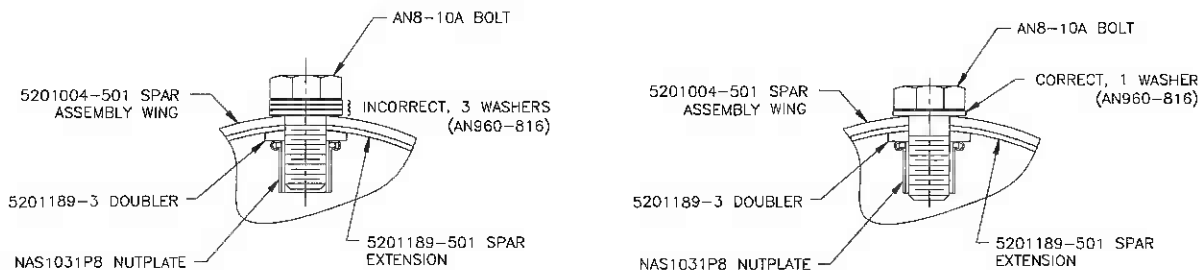
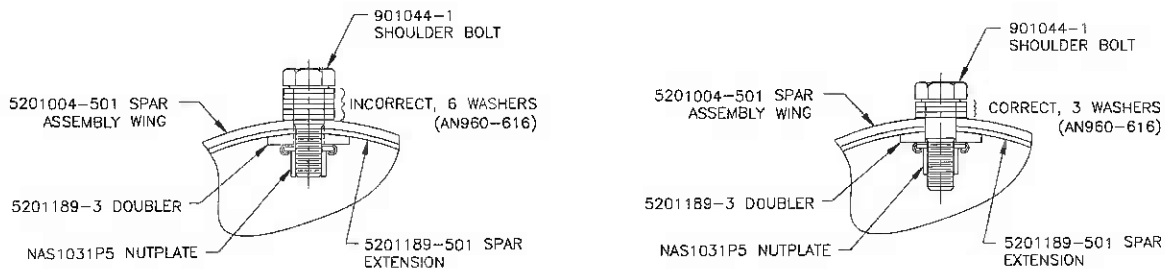

Figure 2

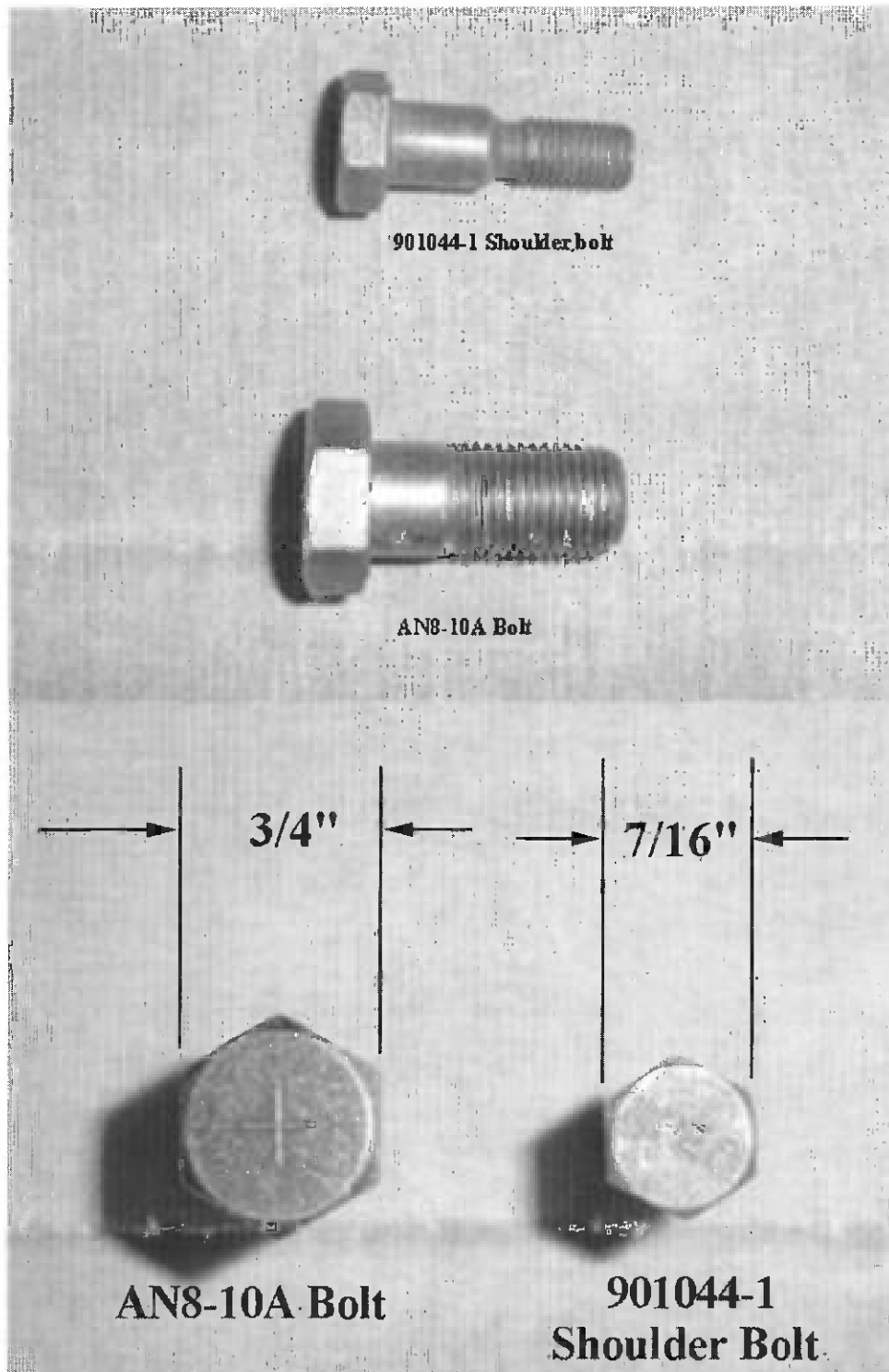

Figure 3

Tiger Aircraft, LLC
226 Pilot Way
Martinsburg, WV 25401

Phone: 304-267-1000
Fax: 304-262-0069